



Information on the processing of personal data by CPI Hungary Investments Kft.

Introduction

Below you will find information on the processing of your personal data by **CPI Hungary Investments Kft.**, Corporate ID No. 01-09-663791, with its registered office at 1139 Budapest, Váci út 99-105. Balance Hall Office Building 6th floor (hereinafter the **“Company”**) provided in accordance with Regulation (EU) 2016/679 of the European Parliament and of the Council of 27 April 2016 on the protection of natural persons with regard to the processing of personal data and on the free movement of such data (hereinafter the **“GDPR”**) and related applicable data protection legislation.

The Company, as a controller of your personal data, determines the means and purposes of the processing of your personal data as specified below in this document. With regard to the processing of personal data, you can also exercise the below-mentioned rights towards the Company.

You can contact the Company in writing at the address 1139 Budapest, Váci út 99-105. Balance Hall Office Building 6th floor, by phone at +36-1-225-6600, or via email at hungary@cpipg.com.

You can contact the Company’s Data Protection Officer via email at dpo@cpipg.com.

Processing of your personal data

The Company processes your personal data only to the necessary extent and for the period necessary to achieve a specific purpose on a lawful basis.

Below you will find an overview of the purposes for which the Company processes your personal data, including a description of the processing purpose. Each purpose of processing also includes information on:

- Lawful basis for processing of your personal data for the given purpose;
- Extent of processing;
- Source of the personal data;
- Information on who can obtain access to your personal data; and
- Information on how long the Company will store your personal data.

In case your personal data are processed on the lawful basis of legitimate interest of the Company or a third party, information on the nature of this legitimate interest is also included.

1. Camera surveillance

Purpose of the processing	Operation of camera surveillance
Description of the purpose of the processing	<p>The Company is operating a camera surveillance system within the territory of Quadra Office Building located at 1132 Budapest, Váci út 30. (the “Office Building”), as well as the parking area of the Office Building for the protection of the Office Building and the tenants of the Office Building on the basis of of Act CXXXIII of 2005 on the personal and property protection, as well as private investigation activity (the “Act”). The location of the cameras is indicated in <u>Annex No. 1</u> of this memorandum.</p> <p>The Company does not match any natural person to the license plates of the cars entering into and parking in the parking area of the Office Building, thus the Company does not perform any data processing activity in that regard (excluding the</p>

case when the Company concluded a lease agreement in relation to certain parking places of the parking area with a natural person, in which case the information memorandum relating to the parking place lease agreement shall be applied).

Lawful basis	The legitimate interest of the Company for the protection of the Office building owned by the Company and the tenants of the Office Building (GDPR Article 6 paragraph (1) subparagraph f)).
Category of personal data	Image of the data subject
Source of personal data	Natural person entering the premises of the Office Building (including the parking area of Office Building) (data subject)
Recipients of personal data	<p>KONA-SEC Kft. (székhely: 1211 Budapest, Weiss Manfréd út 5-7.; e-mail: info@konasec.hu) as the security company acting on the basis of the service agreement concluded with the Company and as the security guard under the Act is entitled to view, have access to the recording taken of the data subject as data processor.</p> <p>Freetime Management Kft. (registered seat: 2120 Dunakeszi, Kápolna utca 2. 3. em. 54. ajtó; e-mail: info@ftmanagement.hu; j.gabriella@ftmanagement.hu) as the security company acting on the basis of the service agreement concluded with the Company and as the security guard under the Act is entitled to view, have access to the recording taken of the data subject as data processor.</p> <p>Persons with legitimate interest shall be entitled to view, have access to the recording taken of the data subject.</p>
Storage period of personal data	7 days from the recording

2. Identification of visitors

Purpose of the processing	Identification of visitors
Description of the purpose of the processing	Handing over to the visitor arriving to one of the tenants of Quadra Office Building (the “ Visitor ”) located at 1132 Budapest, Váci út 30. (the “ Office Building ”) an entrance card after (i) the identity check of the Visitor, (ii) the Visitor has provided his/her personal data specified below, and (iii)

providing the name of the tenant the Visitor is visiting, which entrance card is assigned to the Visitor (the “**Entrance Card**”). The personal data of the Visitor specified below, the entry and exit time, company name of the tenant provided by the Visitor and the number of the Entrance Card are recorded in the entrance journal (the “**Journal**”). The Visitor can only enter the Office Building if he/she possesses the Entrance Card and by using it at the electronic entrance system of the Office Building (the “**System**”). The Visitor shall keep the Entrance Card with himself/herself during the time spent in the Office Building and the Visitor shall return the Entrance Card at the reception desk of the Office Building. The use of the Entrance Card is necessary for the entry into the Office Building, while personal data for the issuance of the Entrance Card is necessary for the protection of the Office Building and the tenants of the Office Building.

Lawful basis	<p>The freely given, specific, informed and unambiguous consent of the Visitor (data subject) given by implied conduct (GDPR Article 6 paragraph (1) subparagraph a)).</p> <p>The legitimate interest of the Company for the protection of the Office building owned by the Company and the tenants of the Office Building (GDPR Article 6 paragraph (1) subparagraph f)).</p>
Category of personal data	The name, address of the data subject (Visitor)
Source of personal data	Visitor
Recipients of personal data	<p>KONA-SEC Kft. (székhely: 1211 Budapest, Weiss Manfréd út 5-7.; e-mail: info@konasec.hu) as the security company acting on the basis of the service agreement concluded with the Company and as the security guard under the Act is entitled to view, have access to the personal data of the data subject as data processor.</p> <p>Freetime Management Kft. (registered seat: 2120 Dunakeszi, Kápolna utca 2. 3. em. 54. ajtó; e-mail: info@ftmanagement.hu; j.gabriella@ftmanagement.hu) as the security company acting on the basis of the service agreement concluded with the Company and as the security guard under the Act is entitled to view, have access to the personal data of the data subject as data processor.</p>

Storage period of personal data

In case of occasional entrance for 24 hours the latest calculated from the exit of the Office Building.

Transfers of your personal data to third countries or international organisations

The Company or the recipients to which the Company gives access to your personal data for the above stated purposes will not transfer your personal data to any third countries or international organisations.

Automated decision-making

An automated decision is a decision made by the Company or a recipient to which the Company gives access to your personal data for the above stated purpose, that is based solely on automated processing of your personal data (including profiling) and that produces legal effects concerning you or similarly significantly affects you.

The Company or the recipients to which the Company gives access to your personal data for the above stated purposes will not use your personal data for automated decision-making.

What are your rights with respect to the processing of personal data?

With respect to the processing of your personal data by the Company, you can request the Company:

- To give you access to your personal data, whereby you can obtain, in particular, information whether your personal data are processed, for what purpose, what is the scope of processed data and who has been given access to your personal data, if relevant. You can also be provided with a copy of your personal data undergoing processing;
- To rectify inaccurate or incorrect data or to complete incomplete personal data;
- To erase the personal data, e.g. if the purpose of processing ceases to apply or if your personal data are processed unlawfully;
- To restrict the processing of your personal data;
- To data portability, which allows you to obtain personal data concerning you, which you have provided to the Company, in a structured and machine-readable format either for yourself or for another controller; and
- To make sure that you are not subject to any automated decision-making (you found out whether such decision-making takes place or not in the preceding chapter).

You can also raise an objection against the processing of your personal data, should the processing of your personal data be based on the lawful basis of legitimate interest, or to lodge a complaint with the Office for Personal Data Protection. The contact details are as follows:

Hungarian National Authority for Data Protection and Freedom of Information

1055 Budapest, Falk Miksa utca 9-11.

1363 Budapest, Pf.: 9.

Phone: +36-1-391-1400

www.naih.hu

ugyfelszolgalat@naih.hu

How you can exercise your rights?

You can request the exercise of your rights via a written or oral request. In order to provide sufficient protection of the personal data processed by the Company and to prevent personal data misuse from taking place, the Company has introduced rules for the verification of your identity stated below.

You may request the exercise of your rights by:

Written request

To request the exercise of the particular right in writing, please fill in the request form available at www.cpigroup.hu/pdf/gdpr_hu.pdf?v071 (CPI Property Group, Group Data Protection Policy, Appendix 2). Your signature on the request form needs to be officially certified. Depending on local law, you may be able to have your signature certified e.g. at a notary office, post office, attorney-at-law, consulate or municipal/regional authority. The signature has to be officially certified in a country where the request is submitted to the given CIPG company in person (e.g. in hotel, office or other premises designated by the Company) or sent via mail using a postal services provider. In case of sending the request via mail using a postal service provider in the countries outside of the EEA or the European Union, you may be contacted by the Company in order to further verify your identity.

Oral request

You may also request the exercise of the particular right in person at the Company's registered seat. Your identity will be verified by the Company's designated employee (e.g. at a front desk), based on the submission of one of the following documents: personal ID card, passport or other document with a photo sufficiently eligible to enable your clear identification.

The exercise of your rights shall not affect the rights of third parties.

Please note that should your requests be manifestly unfounded or excessive, in particular because of their repetitive character, the Company may require a reasonable fee, not exceeding the necessary costs of the provision of the above stated information or arranging the exercising of your rights, for the purposes of responding to your request.

Is the provision of your personal data mandatory?

If the Company processes your personal data based on your consent, the processing of such data is voluntary. In this case, you are not required to grant your consent and provide your personal data to the Company.

Your consent to the processing of your personal data must be a freely given, specific, informed and unambiguous expression of your will, whereby you give the Company your permission, in the form of a statement or another evident confirmation, to process your personal data.

The Company may process your personal data based on a different lawful basis, e.g. lawful basis of performance of a contract, of compliance with a legal obligation or for purposes of the legitimate interest. In this situation, provision of your personal data is necessary, because, the Company may need such personal data e.g. to conclude and perform a contract with you or to meet legal obligations. If you decide not to provide the personal data to the Company, it would not be possible to conclude the contract or to fulfil the given legal obligations.

How and when can you withdraw your consent to personal data processing?

You may withdraw the consent you have granted to the Company at any time, even before the end of the period for which it was given.

You may withdraw your consent:

- Electronically via email at hungary@cpig.com; or
- In writing at the following address:
1139 Budapest, Váci út 99-105. Balance Hall Office Building 6th floor

The withdrawal of your consent shall have no impact on the processing of your personal data conducted before the withdrawal.



Annex No. 1

Location of cameras

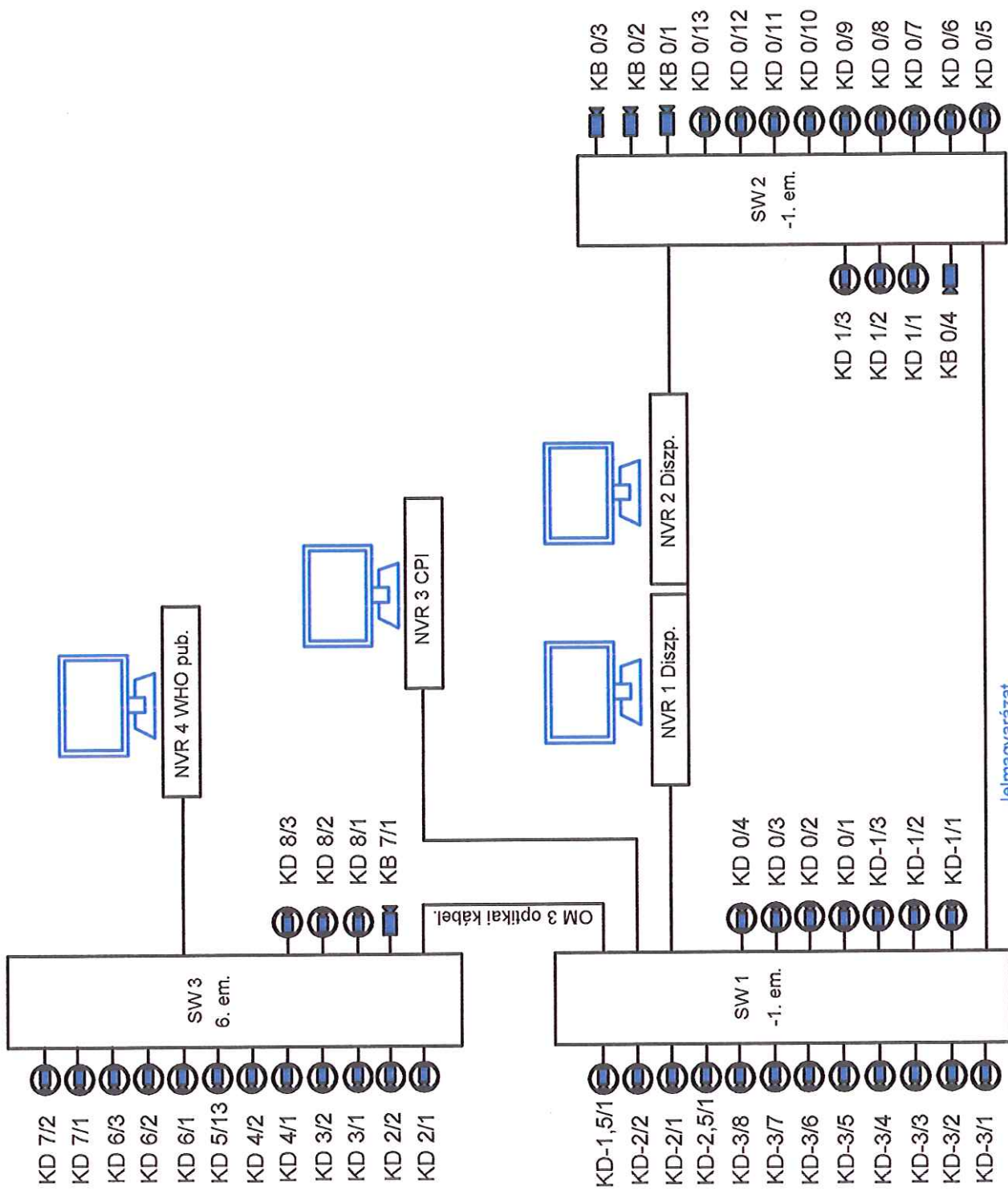

Jelmagyarázat

-  28" LED 4K monitor
 -  IP képrögzítő készülék
 -  Bullet IP kamera
 -  Minidóm IP kamera
- A másként nem jelölt összeköttetések CAT6 UTP kábellel történtek

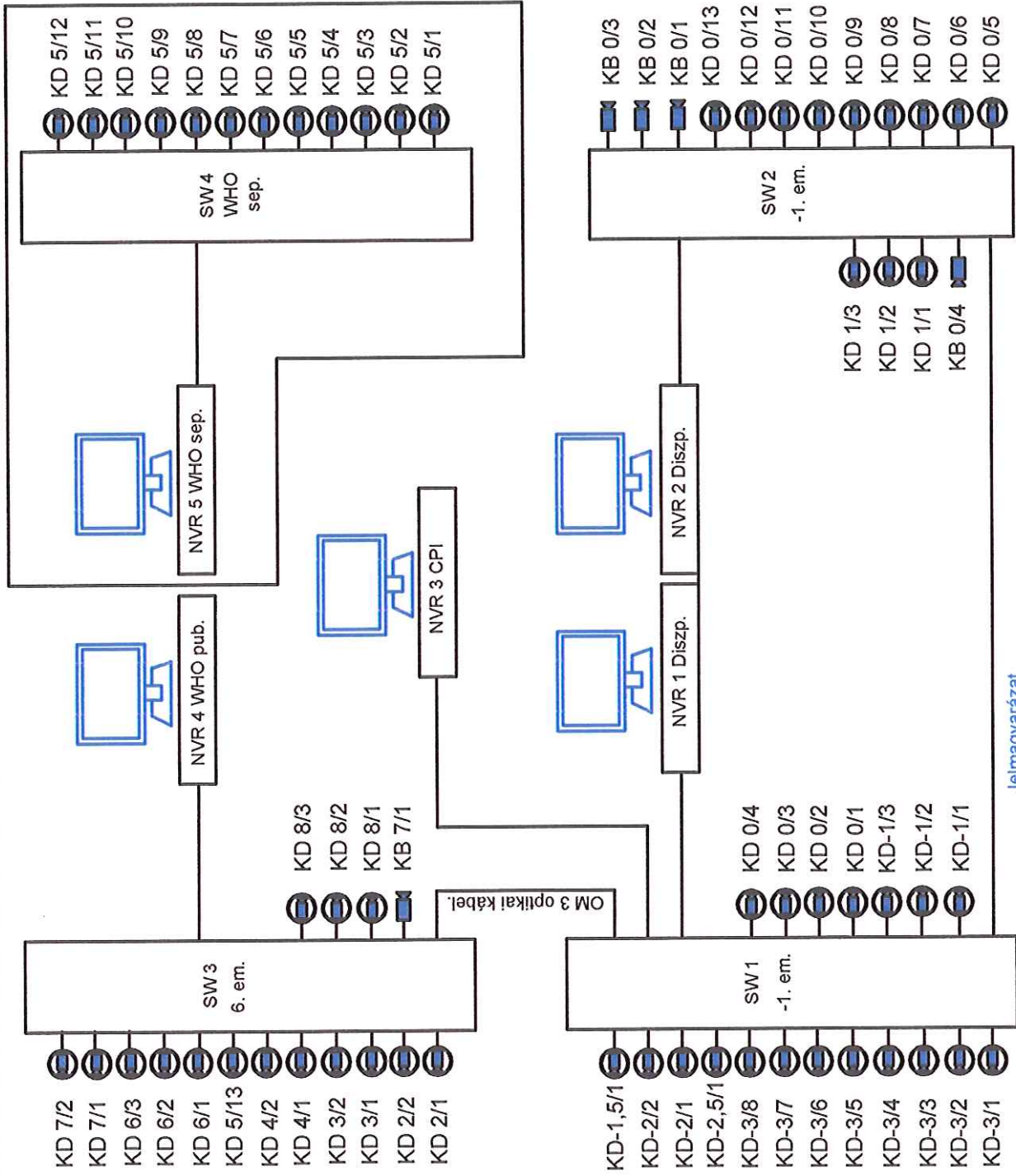

Jelmagyarázat

-  28" LED 4K monitor
-  IP képrögzítő készülék
-  Bullet IP kamera
-  Minidóm IP kamera
-  A másként nem jelölt összeköttetések CAT6 UTP kábelrel történtek

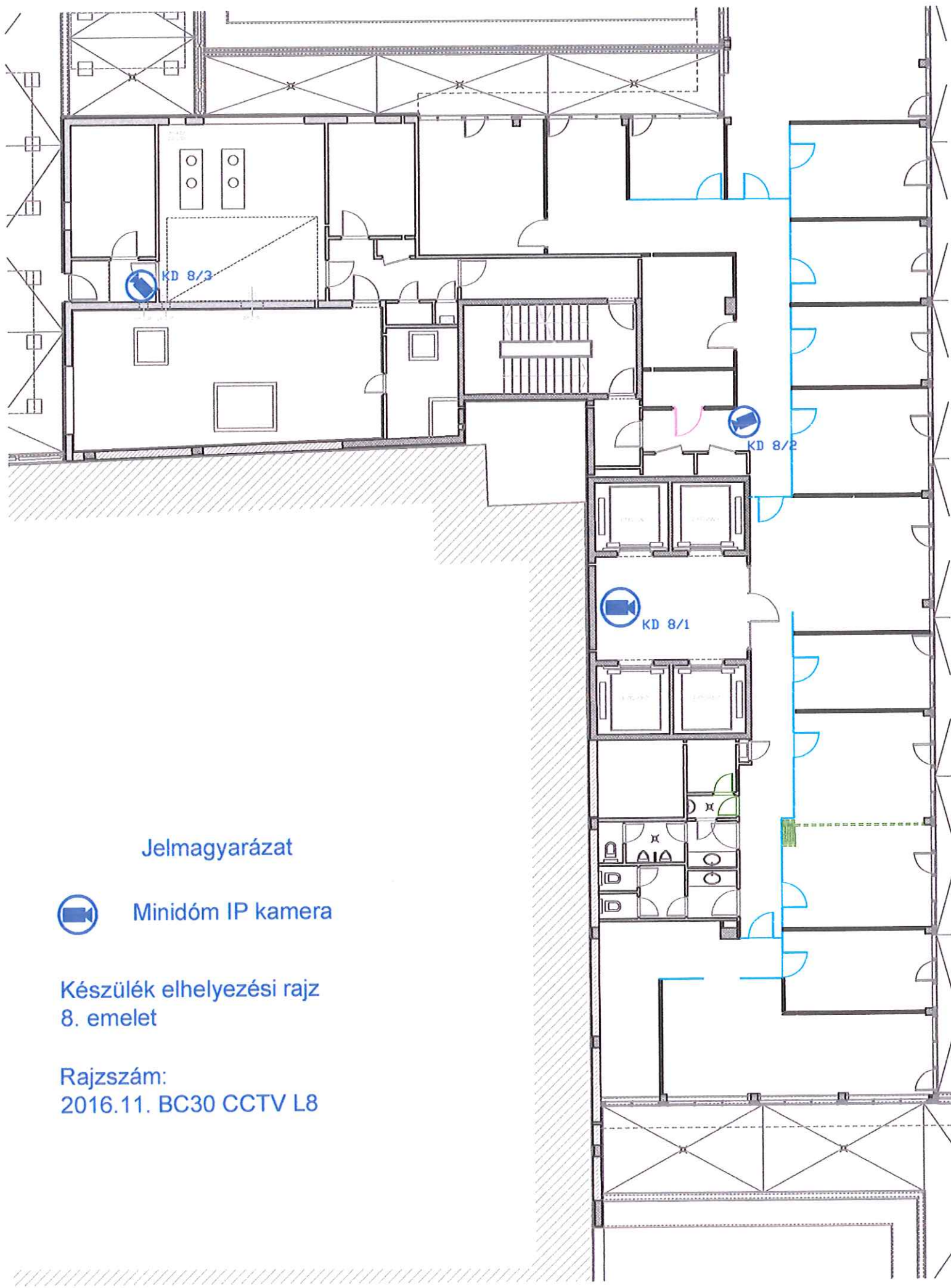

Jelmagyarázat



Minidóm IP kamera

Készülék elhelyezési rajz
8. emelet

Rajzszám:
2016.11. BC30 CCTV L8

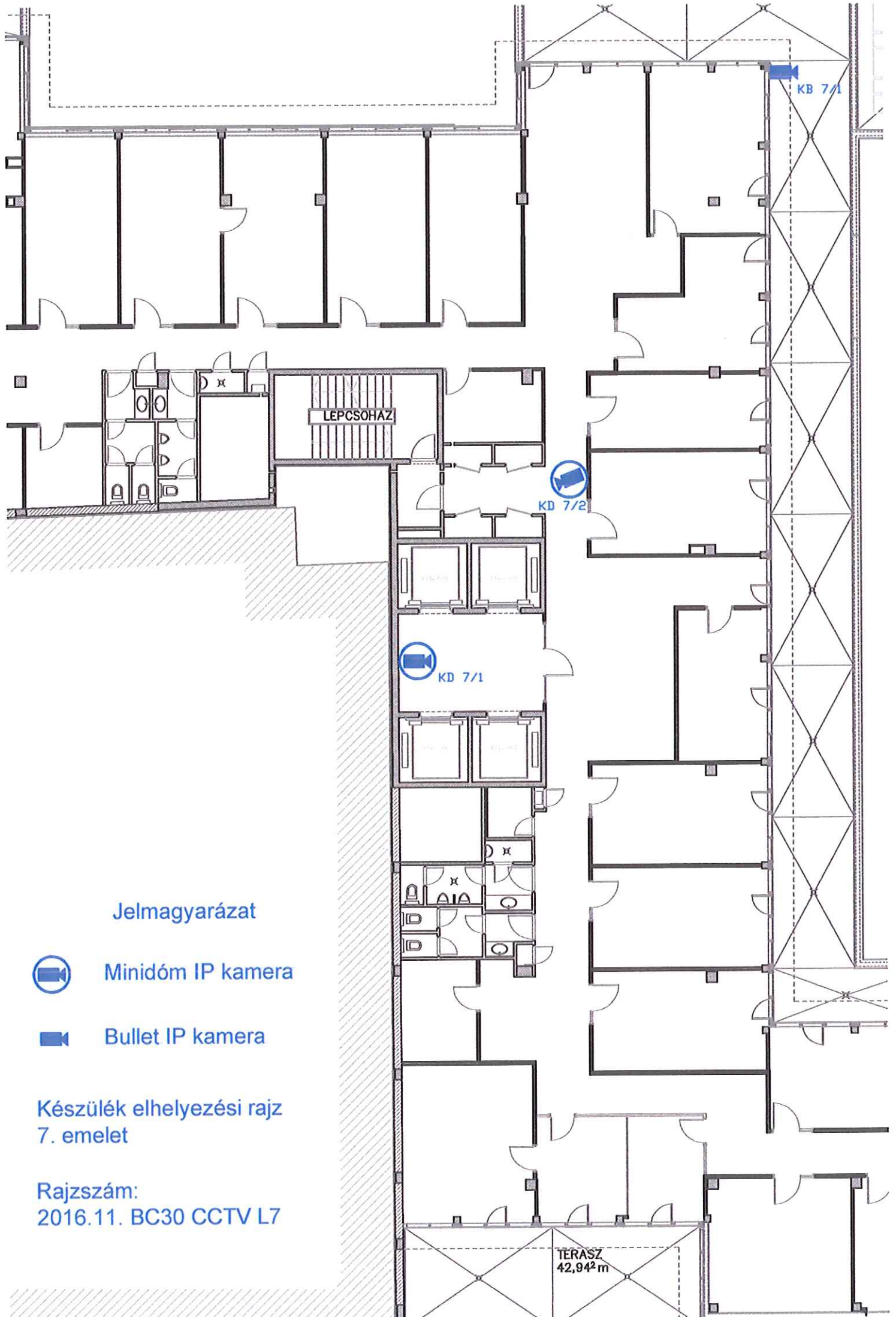

Jelmagyarázat



Minidóm IP kamera



Bullet IP kamera

Készülék elhelyezési rajz
7. emelet

Rajkszám:
2016.11. BC30 CCTV L7

TERASZ
42,94²m

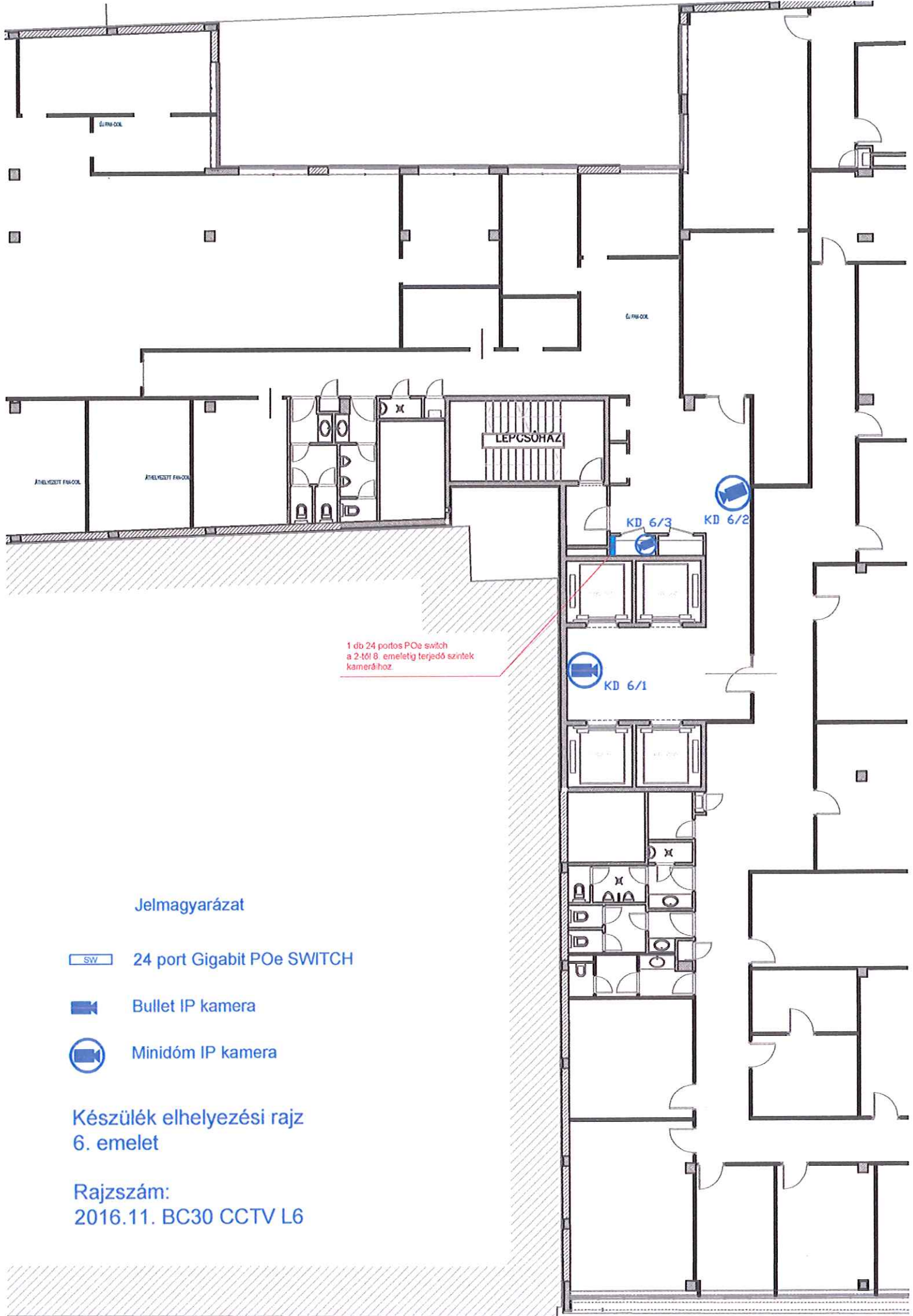

1 db 24 portos PoE switch
a 2-től 8. emeletig terjedő szintek
kameráihoz.

Jelmagyarázat

-  24 port Gigabit PoE SWITCH
-  Bullet IP kamera
-  Minidóm IP kamera

Készülék elhelyezési rajz
6. emelet

Rajkszám:
2016.11. BC30 CCTV L6

Jelmagyarázat



28" LED 4K monitor



IP képrögzítő készülék



24 port Gigabit PoE SWITCH



Bullet IP kamera



Minidóm IP kamera

Készülék elhelyezési rajz
5. emelet

Rajzszám:
2016.11. BC30 CCTV L5

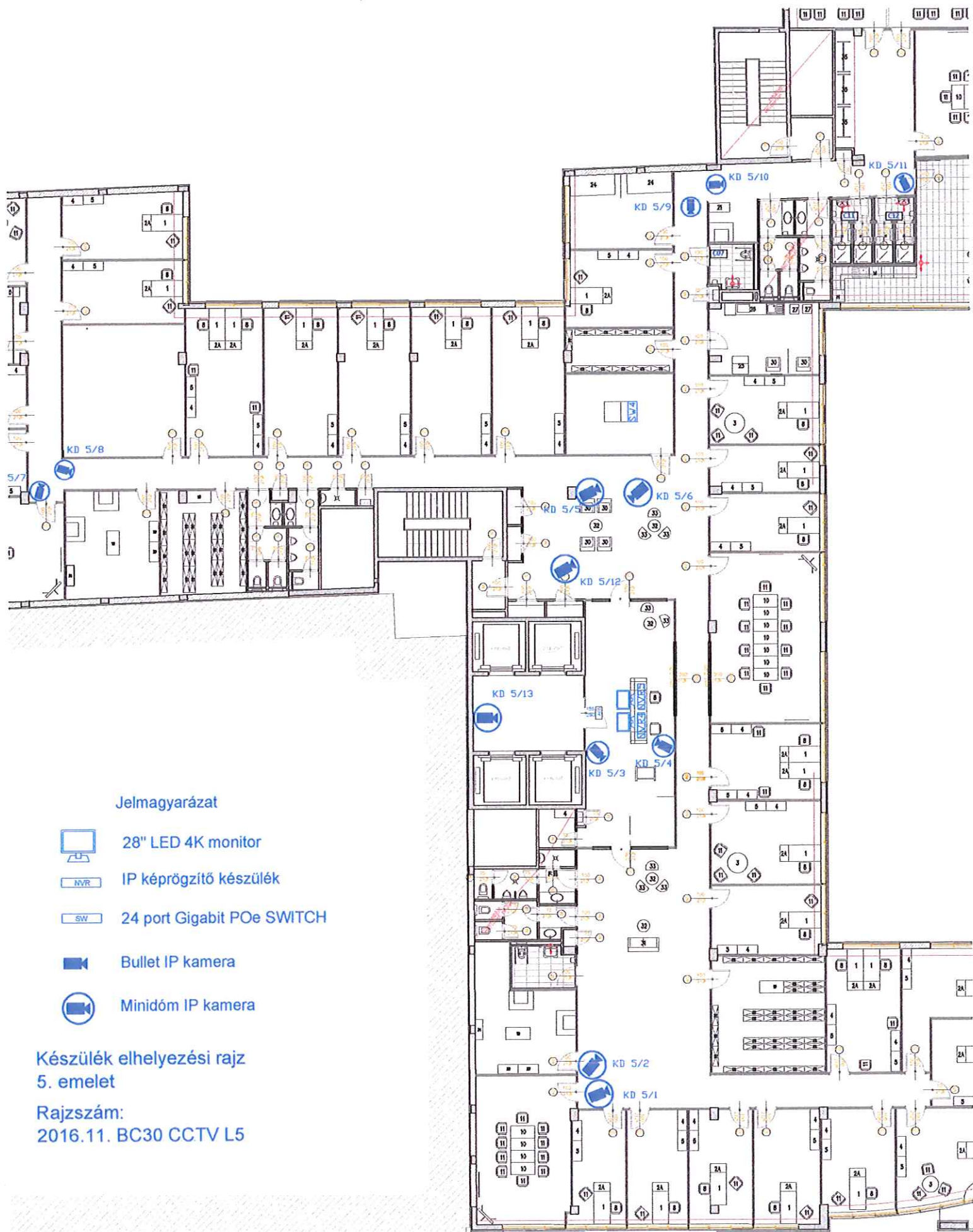

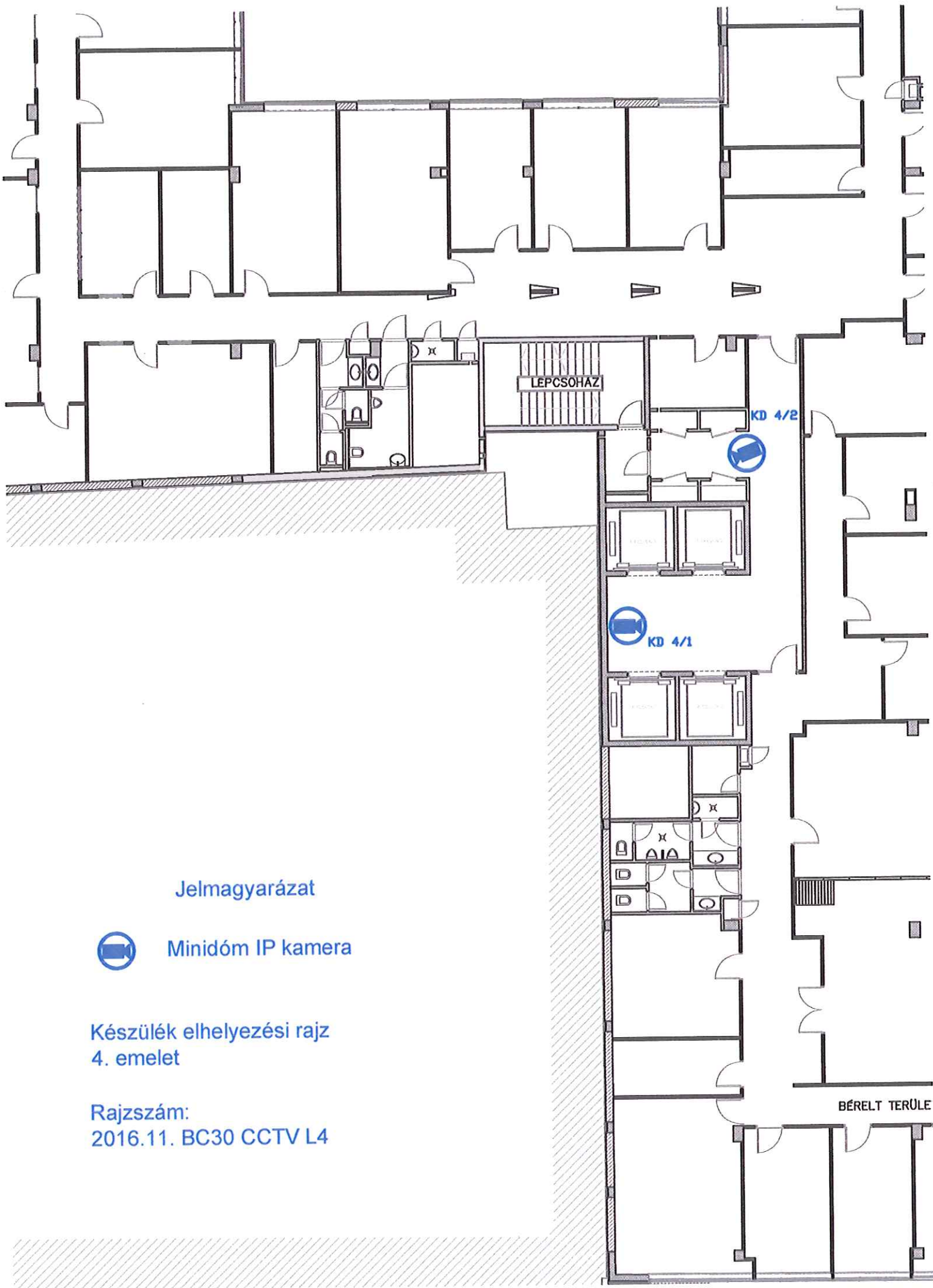

Jelmagyarázat



Minidóm IP kamera

Készülék elhelyezési rajz
4. emelet

Rajzszám:
2016.11. BC30 CCTV L4

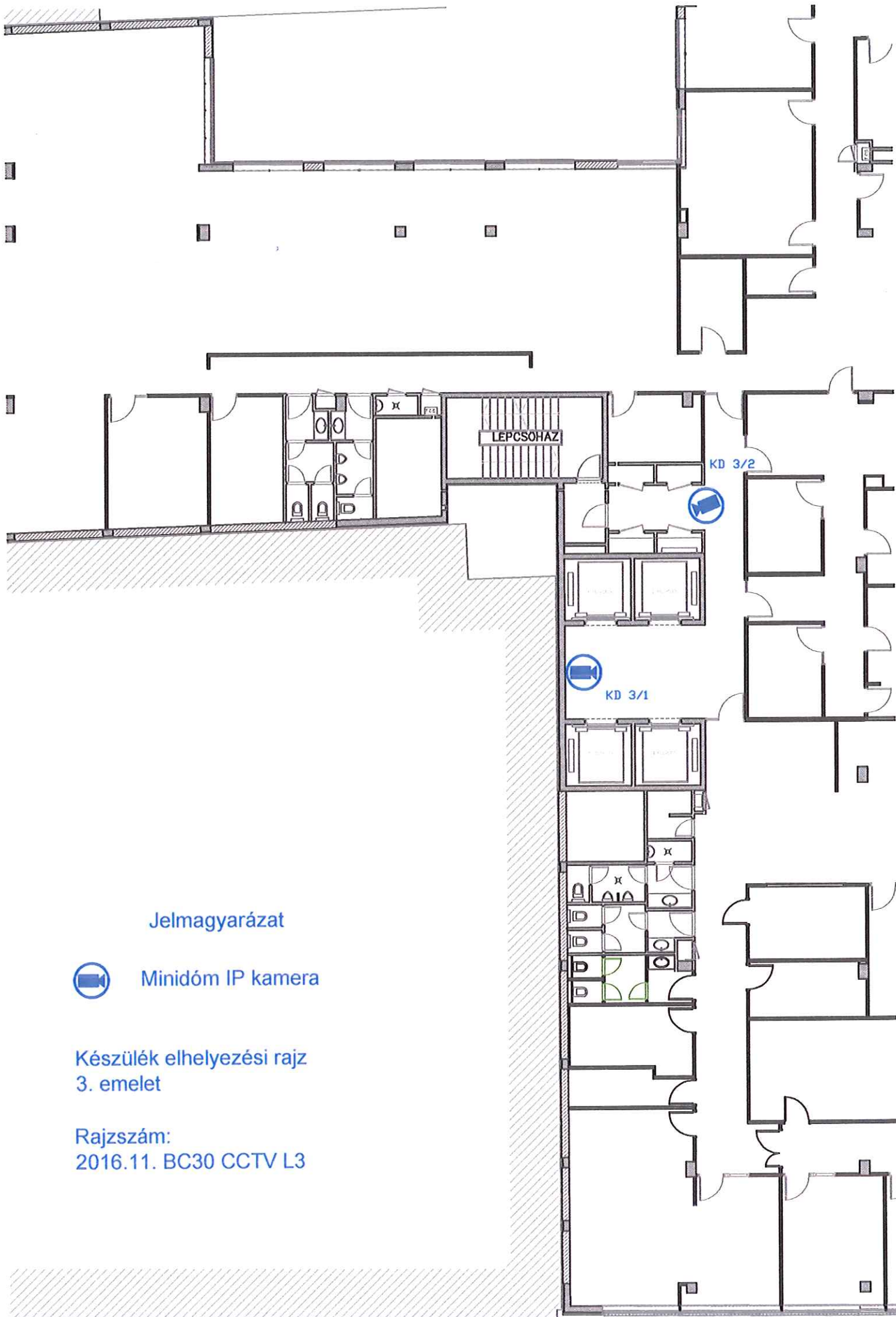

Jelmagyarázat



Minidóm IP kamera

Készülék elhelyezési rajz
3. emelet

Rajzszám:
2016.11. BC30 CCTV L3

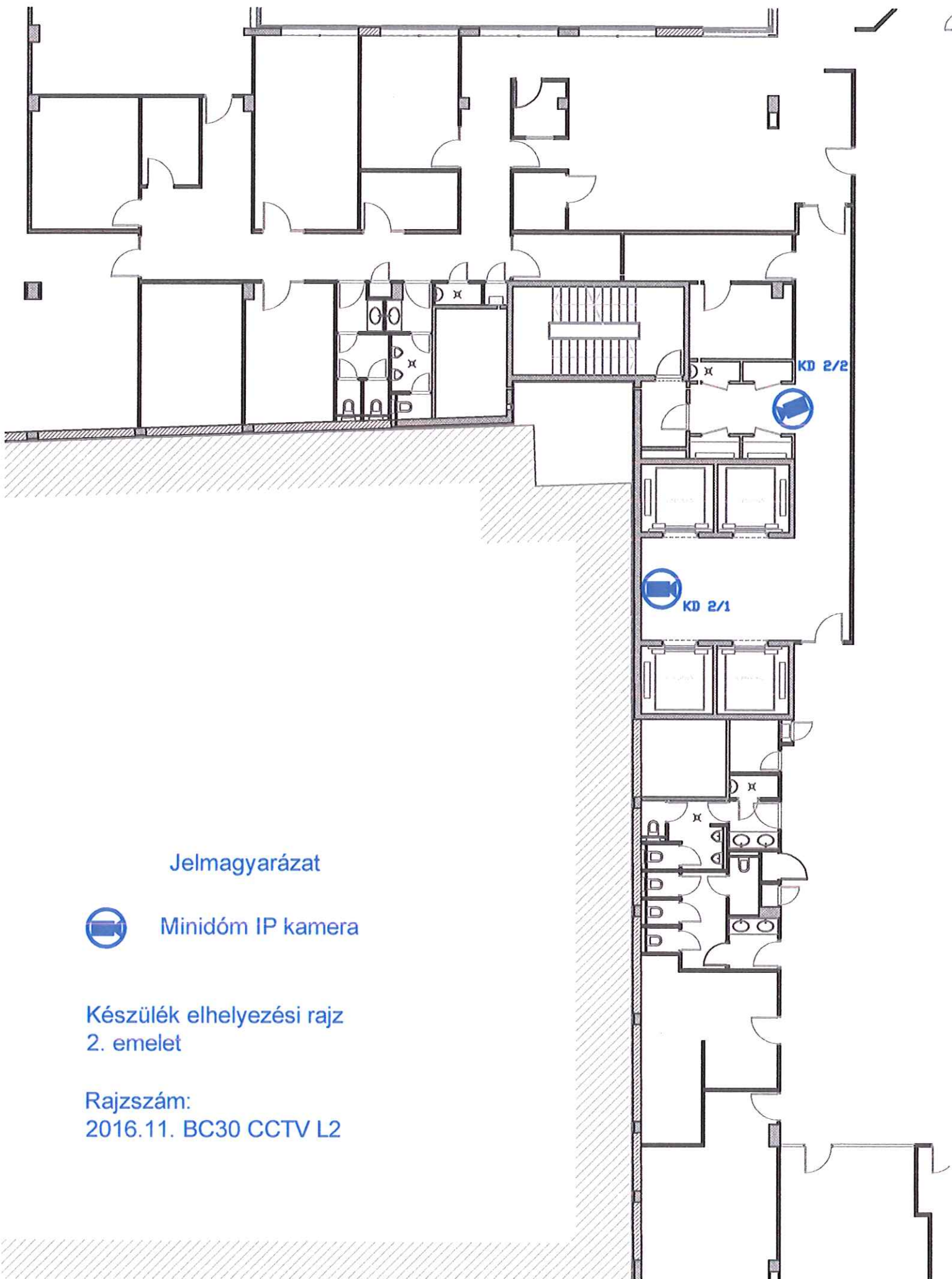

Jelmagyarázat



Minidóm IP kamera

Készülék elhelyezési rajz
2. emelet

Rajzsám:
2016.11. BC30 CCTV L2

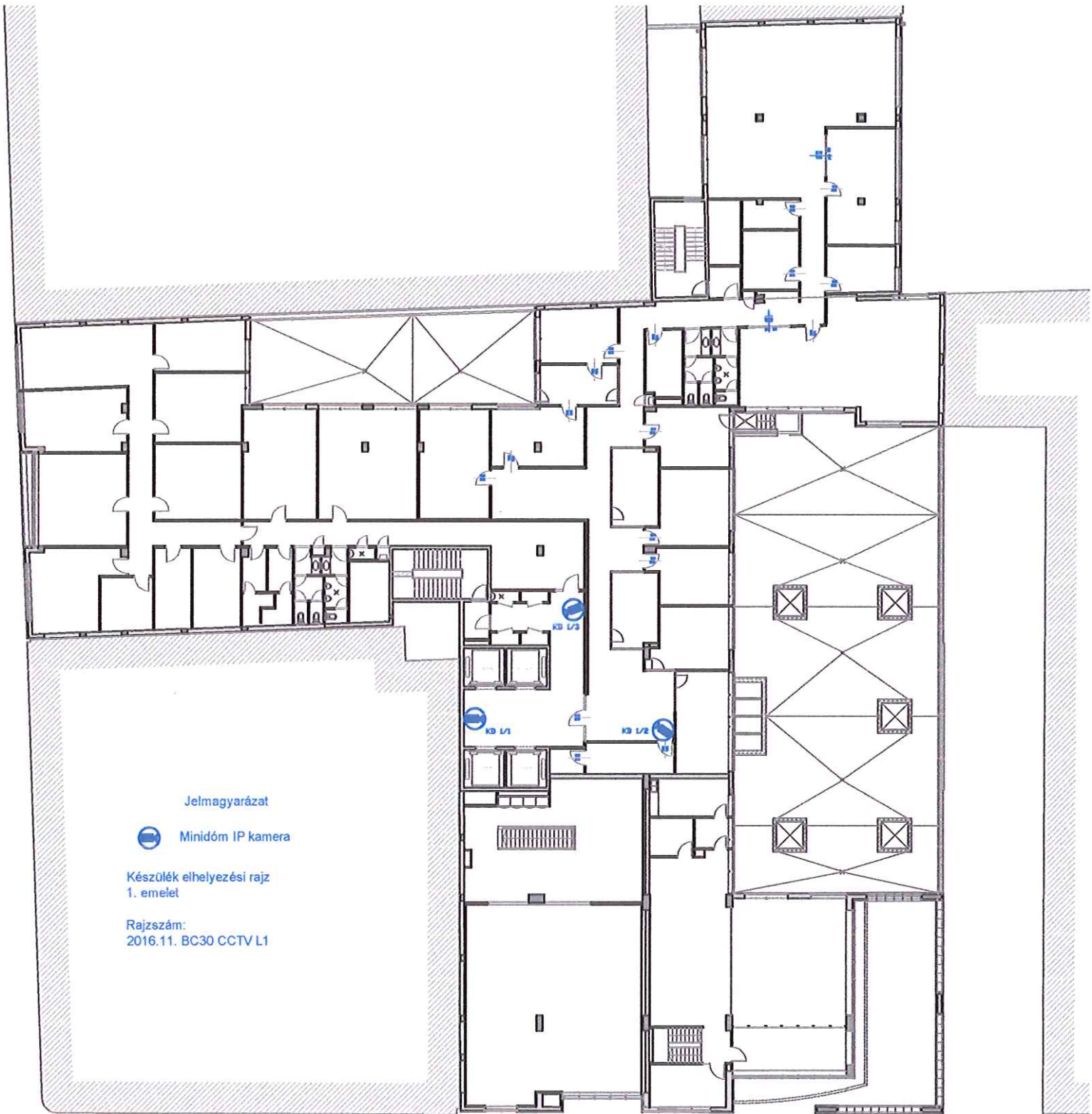

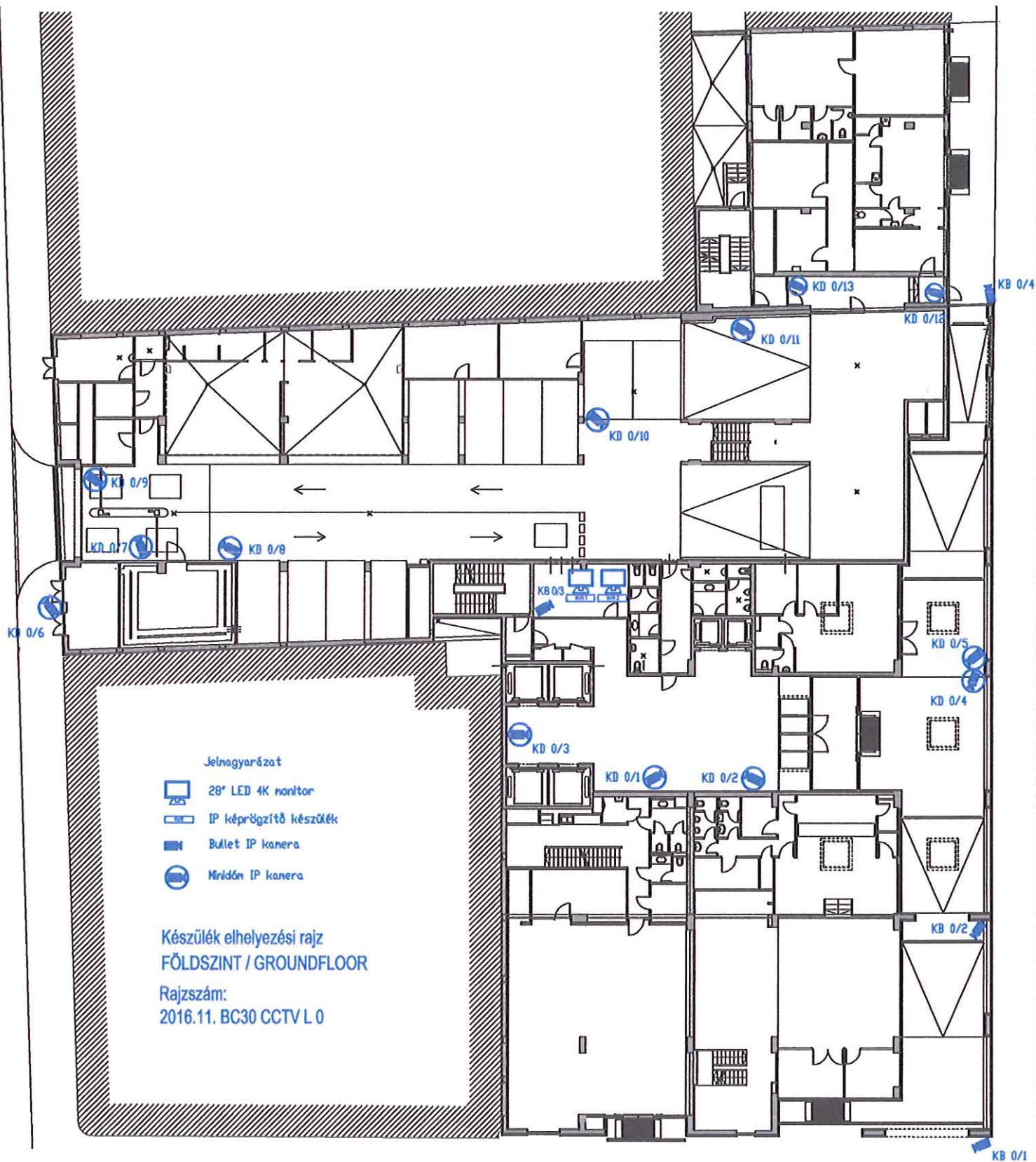

Jelnagyarázat

-  28" LED 4K monitor
-  IP képrögzítő készülék
-  Bullet IP kamera
-  Mindkör IP kamera

Készülék elhelyezési rajz
FÖLDSZINT / GROUND FLOOR

Rajzszám:
2016.11. BC30 CCTV L 0

KB 0/1

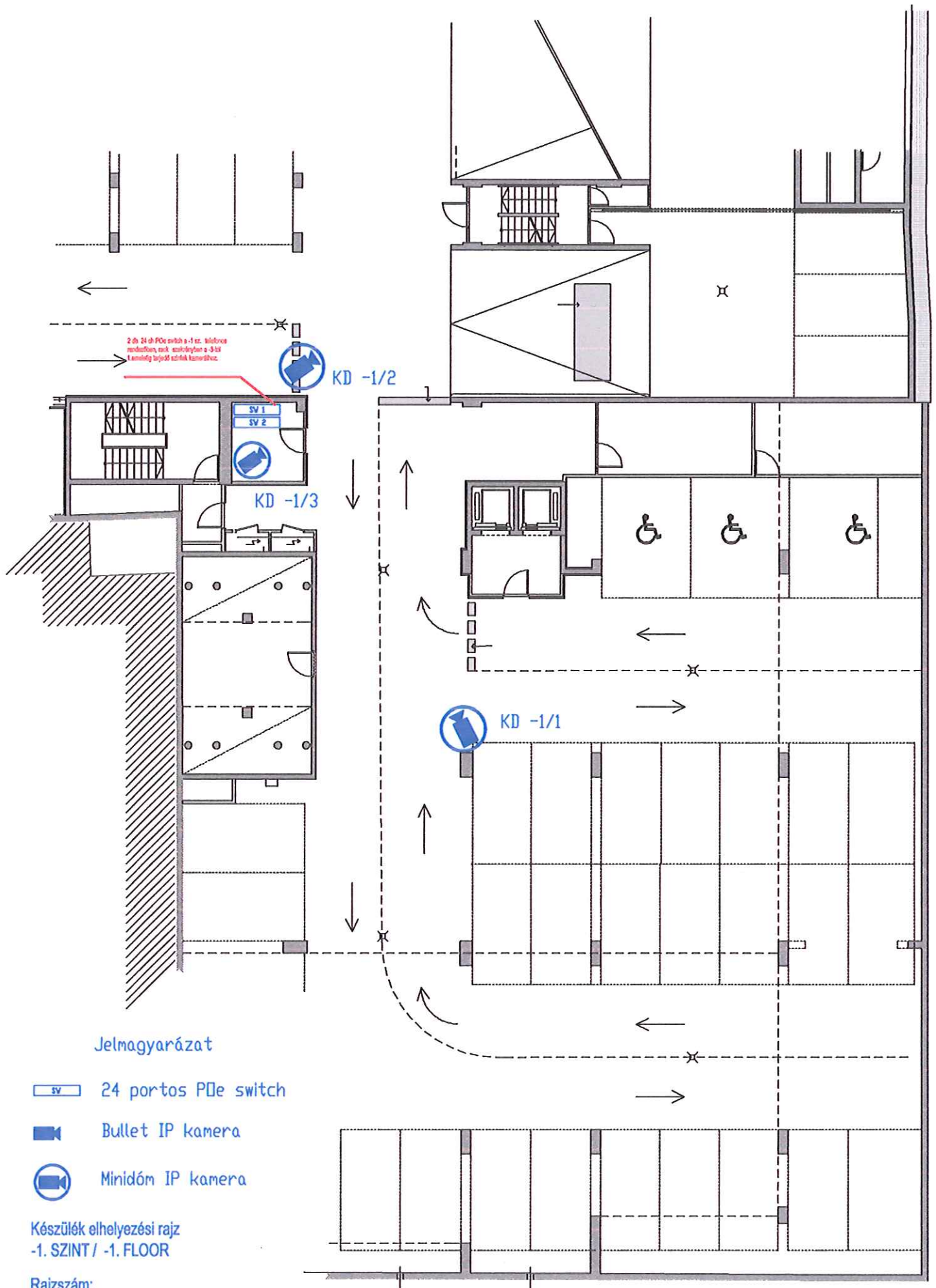

Jelmagyarázat

- SV 24 portos PoE switch
- Bullet IP kamera
- Minidóm IP kamera

Készülék elhelyezési rajz
-1. SZINT / -1. FLOOR

Rajzszám:
2016.11. BC30 CCTV L -1

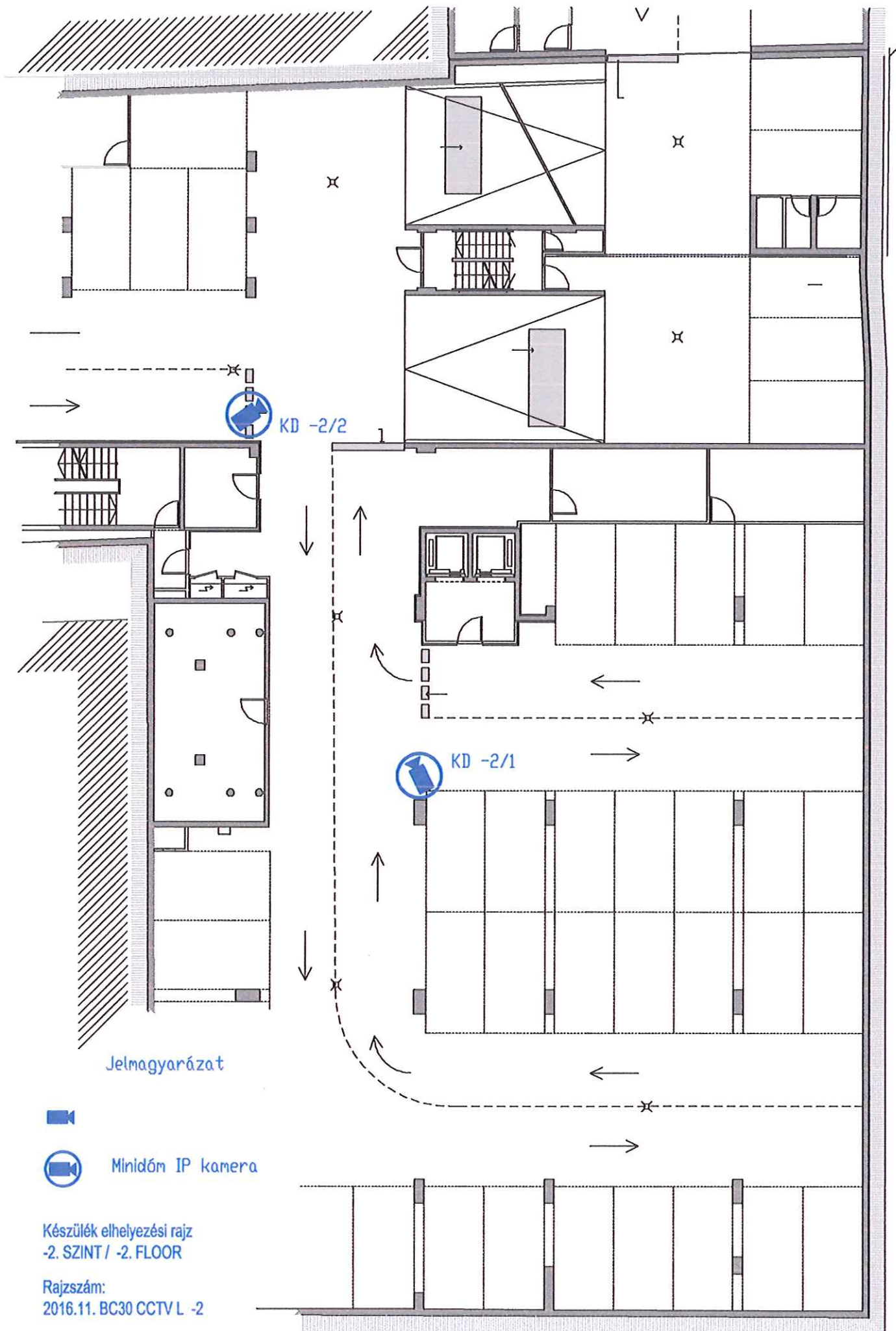

Jelmagyarázat



Minidóm IP kamera

Készülék elhelyezési rajz
-2. SZINT / -2. FLOOR

Rajzszám:
2016.11. BC30 CCTV L -2

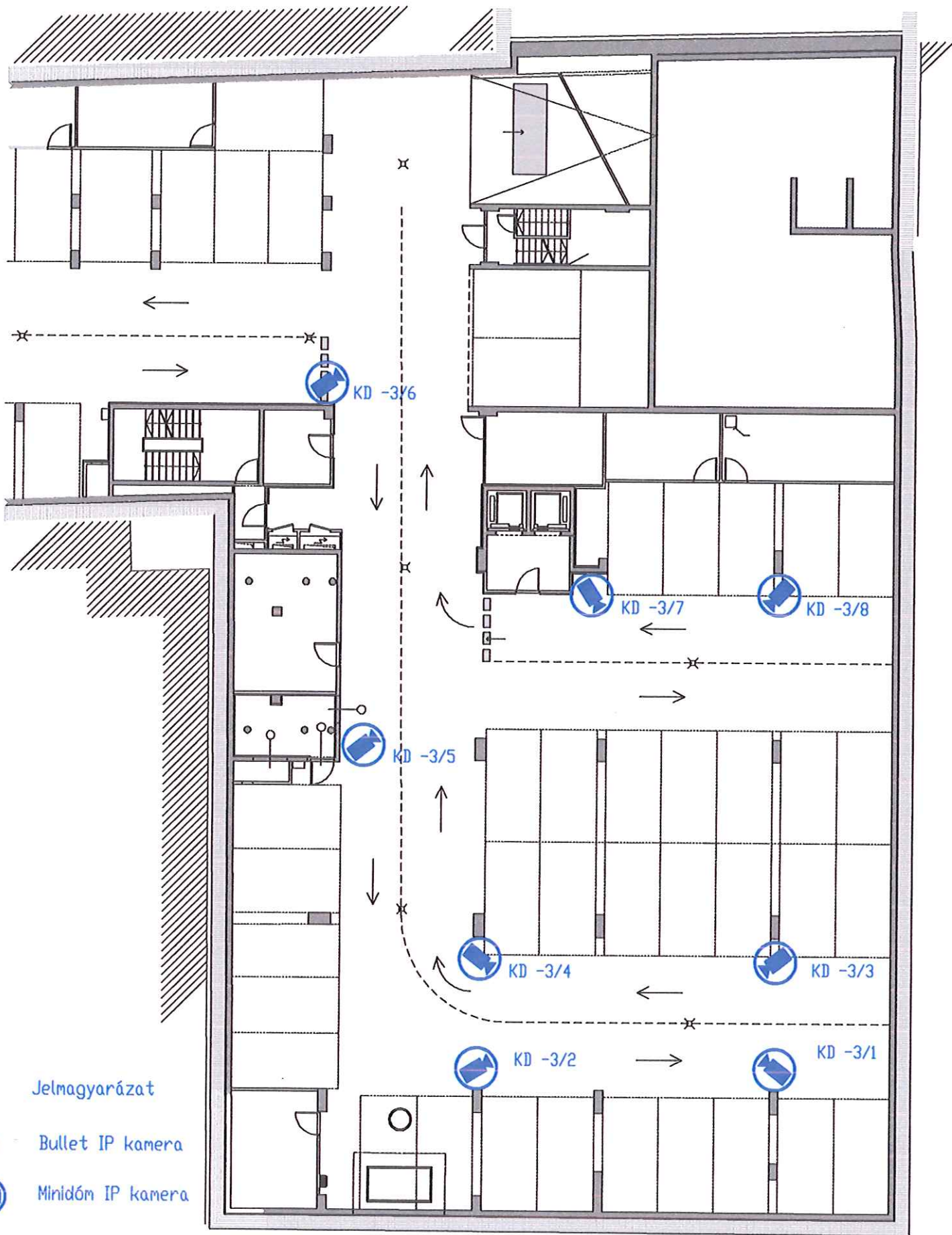

Jelmagyarázat

-  Bullet IP kamera
-  Minidóm IP kamera

Készülék elhelyezési rajz
-3. SZINT / -3. FLOOR

Rajzszám:
2016.11. BC30 CCTV L-3